

TECHNISCHE DATEN

METRISCH

EINSATZBEDINGUNGEN

V MAX 4.0 m/s
 TEMPERATURBEREICH -40°C + 120°C

RAUHTIEFEN

	µmRa	µmRt
GLEITFLÄCHEN Ød ₁	0.1 ↔ 0.4	4 max
STATISCHE FLÄCHEN ØD ₁ ØD ₂	1.6 max	10 max
STIRNFLÄCHEN L ₁	3.2 max	16 max

EINBAUSCHRÄGEN UND RADIIEN

DURCHMESSER Ød ₁ mm	≤ 50	≤ 90	≤ 200	> 200
MAX RADIUS r ₁ mm	0.4	0.4	0.4	0.8
MAX RADIUS r ₂ mm	0.2	0.4	0.6	0.8

TOLERANZEN

	Ød ₁	ØD ₁	ØD ₂	L ₁
mm	f9	H11	H11	+0.2 -0

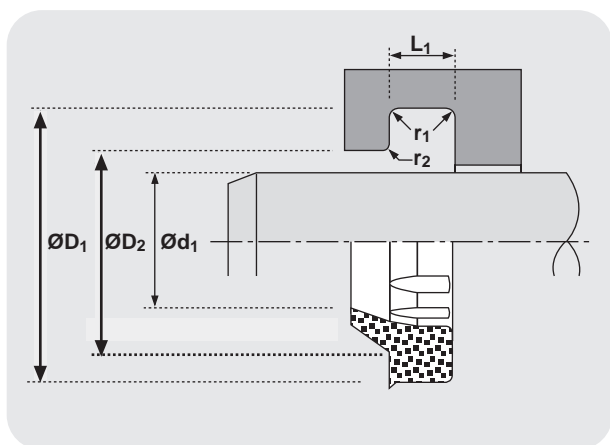

EINBAU

Abstreifer nierenförmig verformen, an einer Stelle in die Nut setzen, dann nachdrücken und Abstreifer einschnappen lassen.

AUFBAU

Die Abstreiflippe des Abstreifers 38 ist derart gestaltet, dass der Kontakt zur Stangenoberfläche erhalten bleibt, um Schmutz, Eis usw. einwandfrei abzustreifen. Die Auslegung des äußeren Teils des Abstreifers bewirkt Festsitz in der Nut und verhindert dort ein Eindringen von Schmutz und Feuchtigkeit. Als Material wird ein Polyester verwendet, das für einen Abstreifer im robusten Einsatz, wie er im Bergbau oder bei Erdbewegungsgeräten vorkommt, notwendig ist.

EIGENSCHAFTEN

- AUßENLIPPE ZUR ABDICHTUNG IM GEHÄUSE
- DRUCKENTLASTET
- FÜR EXTREME BELASTUNG

HINWEIS

Sondermaße -auch größere Durchmesser- können aus den vorhandenen Profilen ohne Formkosten gefertigt werden.

Die mit "‡" gekennzeichneten Artikel passen in Einbauräume nach ISO 6195A.

***Sollten Ihre Betriebsbedingungen von den in den Datenblättern genannten abweichen, *** wenden Sie sich bitte an unsere Technik - wir beraten Sie gern.

Abstreifer

38

metrisch

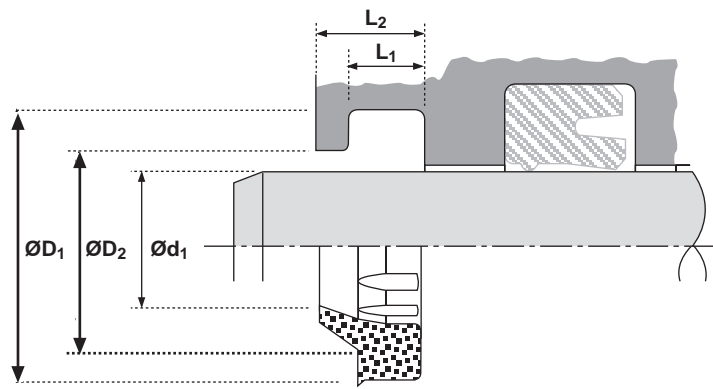

Ød1	TOL f9	ØD1	TOL H11	ØD2	TOL H11	L1 +0.2 - 0	L2	PART No.
18	-0.016 -0.059	24.0	+0.13 +0.00	21.0	+0.13 +0.00	5.0	7.0	4392000
20	-0.020 -0.072	28.0	+0.13 +0.00	25.5	+0.13 +0.00	5.0	8.0	4321900‡
22	-0.020 -0.072	30.0	+0.13 +0.00	27.5	+0.13 +0.00	5.0	8.0	4322000‡
25	-0.020 -0.072	33.0	+0.16 +0.00	30.5	+0.16 +0.00	5.0	8.0	6617700‡
28	-0.020 -0.072	36.0	+0.16 +0.00	33.5	+0.16 +0.00	5.0	8.0	6617800‡
30	-0.020 -0.072	38.0	+0.16 +0.00	35.5	+0.16 +0.00	5.0	8.0	4419200
30	-0.020 -0.072	41.2	+0.16 +0.00	37	+0.16 +0.00	7.5	10.0	4528900
32	-0.025 -0.087	40.0	+0.16 +0.00	37.5	+0.16 +0.00	5.0	8.0	6617900‡
35	-0.025 -0.087	43.0	+0.16 +0.00	40.5	+0.16 +0.00	5.0	8.0	4724800
36	-0.025 -0.087	44.0	+0.16 +0.00	41.5	+0.16 +0.00	5.0	8.0	6618000‡
40	-0.025 -0.087	48.0	+0.16 +0.00	45.5	+0.16 +0.00	5.0	8.0	6618100‡
41.28	-0.025 -0.087	49.28	+0.16 +0.00	46.8	+0.16 +0.00	5.0	8.0	4599900
45	-0.025 -0.087	53.0	+0.19 +0.00	50.5	+0.19 +0.00	5.0	8.0	6618200‡
50	-0.025 -0.087	58.0	+0.19 +0.00	55.5	+0.19 +0.00	5.0	8.0	6618300‡
50	-0.025 -0.087	58.6	+0.19 +0.00	53.0	+0.19 +0.00	5.3	7.0	4300400
50	-0.025 -0.087	60.6	+0.19 +0.00	53.0	+0.19 +0.00	5.3	7.0	4458000
55	-0.025 -0.087	65.6	+0.19 +0.00	58.0	+0.19 +0.00	5.3	7.0	4531401
56	-0.030 -0.104	66.0	+0.19 +0.00	63.0	+0.19 +0.00	6.3	10.0	6618400‡
56	-0.030 -0.104	66.6	+0.19 +0.00	59.0	+0.19 +0.00	5.3	7.0	4458100
60	-0.030 -0.104	70.0	+0.19 +0.00	66.0	+0.19 +0.00	5.3	7.0	4386200
60	-0.030 -0.104	70.0	+0.19 +0.00	67.0	+0.19 +0.00	6.3	10.0	4270200
60	-0.030 -0.104	70.6	+0.19 +0.00	63.0	+0.19 +0.00	5.3	7.0	4456400
63	-0.030 -0.104	73.0	+0.19 +0.00	70.0	+0.19 +0.00	6.3	10.0	6618500‡

Abstreifer

38

metrisch

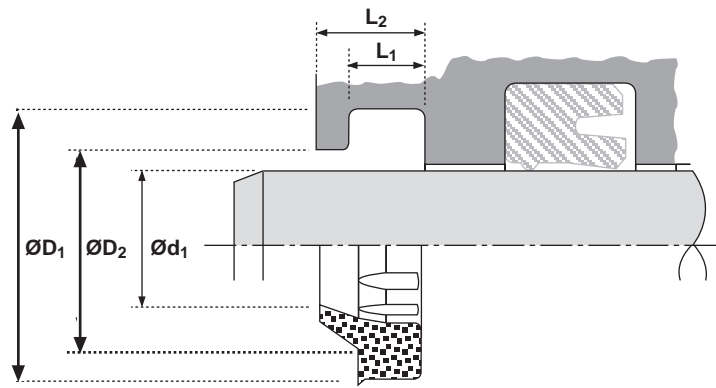

Ød ₁	TOL f9	ØD ₁	TOL H11	ØD ₂	TOL H11	L ₁ +0.2 - 0	L ₂	PART No.
63	-0.030 -0.104	73.6	+0.19 +0.00	66.0	+0.19 +0.00	5.3	7.0	4283600
65	-0.030 -0.104	75.0	+0.19 +0.00	72.0	+0.19 +0.00	6.3	10.0	4343800
70	-0.030 -0.104	80.0	+0.19 +0.00	77.0	+0.19 +0.00	6.3	10.0	6618600‡
70	-0.030 -0.104	80.6	+0.22 +0.00	73.0	+0.19 +0.00	5.3	7.0	4454000
70	-0.030 -0.104	82.2	+0.22 +0.00	76.0	+0.19 +0.00	7.2	12.0	4243900
75	-0.030 -0.104	83.6	+0.22 +0.00	78.0	+0.19 +0.00	5.3	7.0	4539500
75	-0.030 -0.104	85.0	+0.22 +0.00	82.0	+0.22 +0.00	6.3	10.0	4532500
75	-0.030 -0.104	87.2	+0.22 +0.00	81.0	+0.22 +0.00	7.2	12.0	4384400
80	-0.030 -0.104	90.0	+0.22 +0.00	87.0	+0.22 +0.00	6.3	10.0	6618700‡
80	-0.030 -0.104	91.0	+0.22 +0.00	85.0	+0.22 +0.00	7.5	11.0	4493200
80	-0.030 -0.104	92.2	+0.22 +0.00	86.0	+0.22 +0.00	7.2	12.0	4242800
82.6	-0.036 -0.123	92.2	+0.22 +0.00	85.7	+0.22 +0.00	5.3	7.1	4415500
85	-0.036 -0.123	93.6	+0.22 +0.00	88.0	+0.22 +0.00	5.3	7.0	4292100
85	-0.036 -0.123	98.0	+0.22 +0.00	92.0	+0.22 +0.00	7.5	11.5	4332800
88	-0.036 -0.123	100.2	+0.22 +0.00	94.0	+0.22 +0.00	7.2	12.0	4269400
90	-0.036 -0.123	100.0	+0.22 +0.00	97.0	+0.22 +0.00	6.3	10.0	6618800‡
90	-0.036 -0.123	102.2	+0.22 +0.00	96.0	+0.22 +0.00	7.2	12.0	4324500
95	-0.036 -0.123	107.2	+0.22 +0.00	101.0	+0.22 +0.00	7.2	12.0	6667600
100	-0.036 -0.123	110.6	+0.22 +0.00	104.0	+0.22 +0.00	5.3	7.0	4300200
100	-0.036 -0.123	112.2	+0.22 +0.00	106.0	+0.22 +0.00	7.2	12.0	4324600
100	-0.036 -0.123	115.0	+0.22 +0.00	110.0	+0.22 +0.00	9.5	14.0	6618900‡
101.6	-0.036 -0.123	116.6	+0.22 +0.00	111.6	+0.22 +0.00	9.5	14.0	6619010
105	-0.036 -0.123	113.0	+0.22 +0.00	110.5	+0.22 +0.00	5.0	8.0	4290300

Abstreifer

38

metrisch

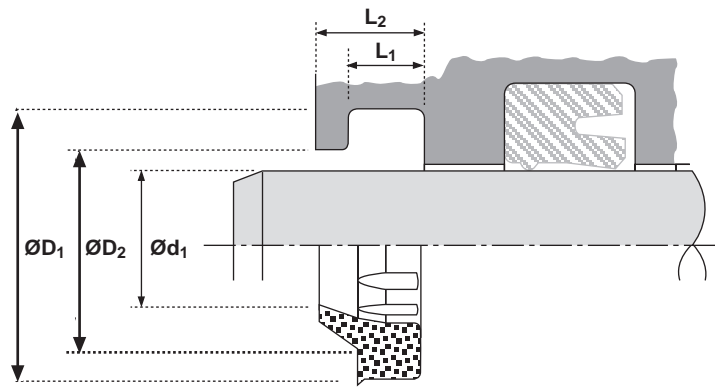

$\varnothing d_1$	TOL f9	$\varnothing D_1$	TOL H11	$\varnothing D_2$	TOL H11	L_1 +0.2 - 0	L_2	PART No.
105	-0.036 -0.123	120.0	+0.22 +0.00	112.0	+0.22 +0.00	7.2	12.0	4539100
110	-0.036 -0.123	122.2	+0.25 +0.00	116.0	+0.22 +0.00	7.2	12.0	4459200‡
110	-0.036 -0.123	125.0	+0.25 +0.00	120.0	+0.22 +0.00	9.5	14.0	6619000‡
115	-0.036 -0.123	127.2	+0.25 +0.00	121.0	+0.25 +0.00	7.2	12.0	4324800
120	-0.036 -0.123	132.2	+0.25 +0.00	126.0	+0.25 +0.00	7.2	12.0	4454300
120	-0.036 -0.123	135.0	+0.25 +0.00	130.0	+0.25 +0.00	9.5	14.0	4385600
125	-0.043 -0.143	133.0	+0.25 +0.00	130.8	+0.25 +0.00	5.3	7.0	4393000
125	-0.043 -0.143	137.2	+0.25 +0.00	131.0	+0.25 +0.00	7.7	12.0	4233500
125	-0.043 -0.143	140.0	+0.25 +0.00	135.0	+0.25 +0.00	9.5	14.0	6619100‡
128	-0.043 -0.143	143.0	+0.25 +0.00	138.0	+0.25 +0.00	9.5	14.0	4581800
130	-0.043 -0.143	142.2	+0.25 +0.00	136.0	+0.25 +0.00	7.2	12.0	4304300
132	-0.043 -0.143	144.2	+0.25 +0.00	138.0	+0.25 +0.00	7.2	12.0	4269500
135	-0.043 -0.143	150.0	+0.25 +0.00	145.0	+0.25 +0.00	9.5	14.0	4278700
140	-0.043 -0.143	152.2	+0.25 +0.00	146.0	+0.25 +0.00	7.7	12.0	4324900
140	-0.043 -0.143	155.0	+0.25 +0.00	150.0	+0.25 +0.00	9.5	14.0	6619200‡
145	-0.043 -0.143	153.6	+0.25 +0.00	148.0	+0.25 +0.00	5.3	7.0	4732200
145	-0.043 -0.143	160.0	+0.25 +0.00	155.0	+0.25 +0.00	9.5	14.0	4560600
150	-0.043 -0.143	162.2	+0.25 +0.00	156.0	+0.25 +0.00	7.7	12.0	4278900
150	-0.043 -0.143	165.0	+0.25 +0.00	158.6	+0.25 +0.00	7.2	12.0	6668500
150	-0.043 -0.143	165.0	+0.25 +0.00	158.6	+0.25 +0.00	10.2	12.0	4342500
150	-0.043 -0.143	166.0	+0.25 +0.00	161.0	+0.25 +0.00	8.0	12.0	4336700
155	-0.043 -0.143	163.0	+0.25 +0.00	160.5	+0.25 +0.00	5.0	8.0	4290200
155	-0.043 -0.143	167.2	+0.25 +0.00	161.0	+0.25 +0.00	7.7	12.0	4288200

Abstreifer

38

metrisch

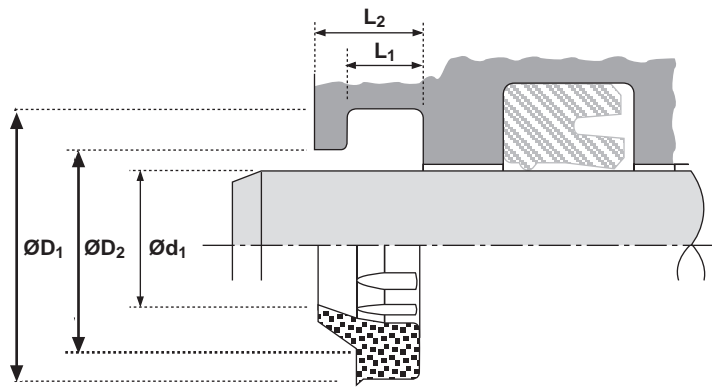

Ød1	TOL f9	ØD1	TOL H11	ØD2	TOL H11	L1 +0.2 - 0	L2	PART No.
155	-0.043 -0.143	175.0	+0.25 +0.00	165.0	+0.25 +0.00	10.2	18.0	4226400
160	-0.043 -0.143	172.2	+0.25 +0.00	166.0	+0.25 +0.00	7.7	12.0	4405700
160	-0.043 -0.143	175.0	+0.25 +0.00	170.0	+0.25 +0.00	9.5	14.0	6619300‡
160	-0.043 -0.143	175.0	+0.25 +0.00	167.0	+0.25 +0.00	10.2	16.0	4454100
165	-0.043 -0.143	180.0	+0.25 +0.00	175.0	+0.25 +0.00	9.5	14.0	4537000
170	-0.043 -0.143	182.2	+0.29 +0.00	176.0	+0.25 +0.00	7.7	12.0	4233600
170	-0.043 -0.143	180.6	+0.29 +0.00	174.0	+0.25 +0.00	5.3	7.0	4732300
170	-0.043 -0.143	185.0	+0.29 +0.00	180.0	+0.25 +0.00	9.5	14.0	4745100
177	-0.043 -0.143	192.0	+0.29 +0.00	187.0	+0.29 +0.00	9.5	14.0	4287900
180	-0.043 -0.143	195.0	+0.29 +0.00	190.0	+0.29 +0.00	9.5	14.0	6619400‡
180	-0.043 -0.143	200.0	+0.29 +0.00	190.0	+0.29 +0.00	10.2	18.0	4460900
195	-0.050 -0.165	210.0	+0.29 +0.00	202.5	+0.29 +0.00	10.2	16.0	4325100
200	-0.050 -0.165	208.6	+0.29 +0.00	203.0	+0.29 +0.00	5.3	7.0	4391600
200	-0.050 -0.165	215.0	+0.29 +0.00	210.0	+0.29 +0.00	9.5	14.0	6619500‡
200	-0.050 -0.165	220.0	+0.29 +0.00	210.0	+0.29 +0.00	10.2	18.0	4387100
205	-0.050 -0.165	220.0	+0.29 +0.00	215.0	+0.29 +0.00	9.5	14.0	4560500
210	-0.050 -0.165	225.0	+0.29 +0.00	220.0	+0.29 +0.00	9.5	14.0	4598000
210	-0.050 -0.165	226.0	+0.29 +0.00	221.0	+0.29 +0.00	8.0	12.0	4336600
210	-0.050 -0.165	230.0	+0.29 +0.00	220.0	+0.29 +0.00	10.2	18.0	4325300
212	-0.050 -0.165	232.0	+0.29 +0.00	225.5	+0.29 +0.00	12.5	18.0	4293900
220	-0.050 -0.165	235.0	+0.29 +0.00	227.6	+0.29 +0.00	10.2	16.0	4325400
220	-0.050 -0.165	240.0	+0.29 +0.00	233.5	+0.29 +0.00	12.5	18.0	6619600‡
225	-0.050 -0.165	240.0	+0.29 +0.00	235.0	+0.29 +0.00	9.5	14.0	4287800

Abstreifer

38

metrisch

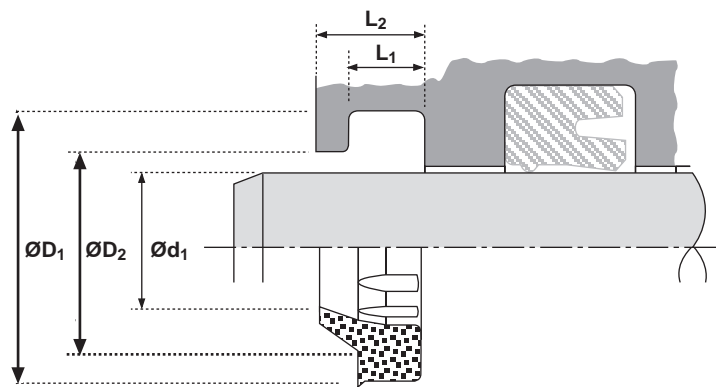

Ød1	TOL f9	ØD1	TOL H11	ØD2	TOL H11	L1 +0.2 - 0	L2	PART No.
225	-0.050 -0.165	245.0	+0.29 +0.00	235.0	+0.29 +0.00	10.2	18.0	4325500
230	-0.050 -0.165	238.6	+0.29 +0.00	233.0	+0.29 +0.00	5.3	7.0	4514000
230	-0.050 -0.165	246.0	+0.29 +0.00	240.7	+0.29 +0.00	7.5	12.0	4290700
230	-0.050 -0.165	250.0	+0.29 +0.00	240.0	+0.29 +0.00	10.2	18.0	4325600
235	-0.050 -0.165	255.0	+0.32 +0.00	245.0	+0.29 +0.00	10.2	18.0	4325700
240	-0.050 -0.165	255.0	+0.32 +0.00	250.0	+0.29 +0.00	9.5	14.0	4745200
240	-0.050 -0.165	260.0	+0.32 +0.00	250.0	+0.29 +0.00	10.2	18.0	4520900
245	-0.050 -0.165	265.0	+0.32 +0.00	258.5	+0.32 +0.00	12.5	18.0	4539600
250	-0.050 -0.165	270.0	+0.32 +0.00	260.0	+0.32 +0.00	10.2	18.0	4460100
250	-0.050 -0.165	270.0	+0.32 +0.00	263.5	+0.32 +0.00	12.5	18.0	6619700‡
255	-0.056 -0.186	270.0	+0.32 +0.00	265.0	+0.32 +0.00	9.5	14.0	4578200
260	-0.056 -0.186	275.0	+0.32 +0.00	270.0	+0.32 +0.00	9.5	14.0	4573100
260	-0.056 -0.186	280.0	+0.32 +0.00	270.5	+0.32 +0.00	10.2	18.0	4325900
265	-0.056 -0.186	285.0	+0.32 +0.00	275.0	+0.32 +0.00	10.2	15.0	4560400
270	-0.056 -0.186	278.6	+0.32 +0.00	273.0	+0.32 +0.00	5.3	7.0	4391700
280	-0.056 -0.186	295.0	+0.32 +0.00	290.0	+0.32 +0.00	9.5	14.0	4716100
285	-0.056 -0.186	305.0	+0.32 +0.00	298.5	+0.32 +0.00	12.5	18.0	4537100
288	-0.056 -0.186	308.0	+0.32 +0.00	301.5	+0.32 +0.00	10.2	15.0	4265300
290	-0.056 -0.186	310.0	+0.32 +0.00	303.5	+0.32 +0.00	12.5	18.0	4467300
295	-0.056 -0.186	315.0	+0.32 +0.00	308.5	+0.32 +0.00	12.5	18.0	4598100
300	-0.056 -0.186	316.0	+0.36 +0.00	310.7	+0.32 +0.00	7.5	12.0	4290800
300	-0.056 -0.186	320.0	+0.36 +0.00	313.5	+0.32 +0.00	12.5	18.0	4525300
305	-0.056 -0.186	325.0	+0.36 +0.00	318.5	+0.36 +0.00	12.5	18.0	4473200

Abstreifer

38

metrisch

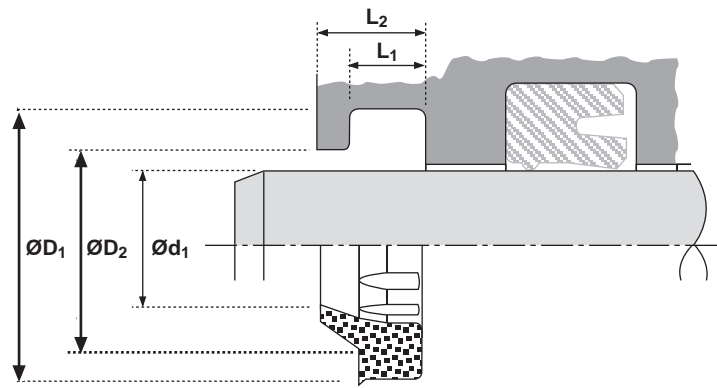

$\varnothing d_1$	TOL f9	$\varnothing D_1$	TOL H11	$\varnothing D_2$	TOL H11	L_1 +0.2 - 0	L_2	PART No.
320	-0.062 -0.202	340.0	+0.36 +0.00	330.0	+0.36 +0.00	10.2	18.0	4454200
330	-0.062 -0.202	346.0	+0.36 +0.00	340.7	+0.36 +0.00	7.5	12.0	4587300
340	-0.062 -0.202	360.0	+0.36 +0.00	350.0	+0.36 +0.00	10.2	18.0	4732500
350	-0.062 -0.202	370.0	+0.36 +0.00	360.0	+0.36 +0.00	10.2	18.0	4717900
355	-0.062 -0.202	375.0	+0.36 +0.00	365.0	+0.36 +0.00	10.2	18.0	4578300
370	-0.062 -0.202	390.0	+0.36 +0.00	383.5	+0.36 +0.00	12.5	18.0	4579800